



Designation: E2208 – 02 (Reapproved 2018)^{ε1}

Standard Guide for Evaluating Non-Contacting Optical Strain Measurement Systems¹

This standard is issued under the fixed designation E2208; the number immediately following the designation indicates the year of original adoption or, in the case of revision, the year of last revision. A number in parentheses indicates the year of last reapproval. A superscript epsilon (ϵ) indicates an editorial change since the last revision or reapproval.

^{ε1} NOTE—3.1.2 was editorially revised in June 2018.

1. Scope

1.1 The purpose of this document is to assist potential users in understanding the issues related to the accuracy of non-contacting strain measurement systems and to provide a common framework for quantitative comparison of optical systems. The output from a non-contacting optical strain and deformation measurement system is generally divided into optical data and image analysis data. Optical data contains information related to specimen strains and the image analysis process converts the encoded optical information into strain data. The enclosed document describes potential sources of error in the strain data and describes general methods for quantifying the error and estimating the accuracy of the measurements when applying non-contacting methods to the study of events for which the optical integration time is much smaller than the inverse of the maximum temporal frequency in the encoded data (that is, events that can be regarded as static during the integration time). A brief application of the approach, along with specific examples defining the various terms, is given in the Appendix.

1.2 *This international standard was developed in accordance with internationally recognized principles on standardization established in the Decision on Principles for the Development of International Standards, Guides and Recommendations issued by the World Trade Organization Technical Barriers to Trade (TBT) Committee.*

2. Referenced Documents

2.1 ASTM Standards:²

[E8 Test Methods for Tension Testing of Metallic Materials](#)

¹ This guide is under the jurisdiction of ASTM Committee E08 on Fatigue and Fracture and is the direct responsibility of Subcommittee E08.03 on Advanced Apparatus and Techniques.

Current edition approved May 1, 2018. Published June 2018. Originally approved in 2002. Last previous edition approved in 2010 as E2208-02(2010)^{ε1}. DOI: 10.1520/E2208-02R18E01.

² For referenced ASTM standards, visit the ASTM website, www.astm.org, or contact ASTM Customer Service at service@astm.org. For *Annual Book of ASTM Standards* volume information, refer to the standard's Document Summary page on the ASTM website.

[E83 Practice for Verification and Classification of Extensometer Systems](#)

[E251 Test Methods for Performance Characteristics of Metallic Bonded Resistance Strain Gages](#)

[E399 Test Method for Linear-Elastic Plane-Strain Fracture Toughness \$K_{Ic}\$ of Metallic Materials](#)

[E1823 Terminology Relating to Fatigue and Fracture Testing](#)

3. Terminology

3.1 Definitions:

3.1.1 *accuracy*—the quantitative difference between a test measurement and a reference value.

3.1.2 *raw data*—the sampled values of a sensor output.

3.2 Definitions of Terms Specific to This Standard:

3.2.1 *coherent illumination*—light source where the difference in phase is solely a function of optical path differences; interference is a direct consequence.

3.2.2 *decoded data*—measurement information related to the displacement or displacement gradient field.

3.2.3 *decoded data bandwidth*—spatial frequency range of the information after decoding of the optical data.

3.2.4 *derived data*—data obtained through processing of the raw data.

3.2.5 *dynamic range*—the range of physical parameter values for which measurements can be acquired with the measurement system.

3.2.6 *illumination wavelength*—wavelength of illumination, ζ .

3.2.7 *incoherent illumination*—light source with random variations in optical path differences; constructive or destructive interference of waves is not possible.

3.2.8 *maximum temporal frequency of encoded data*—reciprocal of the shortest event time contained in the encoded data (for example, time variations in displacement field).

3.2.9 *measurement noise*—variations in the measurements that are not related to actual changes in the physical property being measured. May be quantified by statistical properties such as standard deviation.

3.2.10 *measurement resolution*—smallest change in the physical property that can be reliably measured.

3.2.11 *numerical aperture, (N.A.)*—non-dimensional measure of diffraction-limitation for imaging system; $N.A. = D/f$ for a simple lens system, where D is lens diameter and f is lens focal length.

3.2.12 *optical data*—recorded images of specimen, containing encoded information related to the displacement or displacement gradient field, or both.

3.2.13 *optical data bandwidth*—spatial frequency range of the optical pattern (for example, fringes, speckle pattern, etc.) that can be recorded in the images without aliasing or loss of information.

3.2.14 *optical integration time*—time over which digital image data is averaged to obtain a discretely sampled representation of the object.

3.2.15 *optical resolution, (OR)*—distance, $d = \zeta / (2 N.A.)$, between a pair of lines that can be quantitatively determined.

3.2.16 *quantization level*—number of bits used in the digital recording of optical data by each sensor for image analysis. The quantization level is one of the parameters determining the fidelity of the recorded optical images. It is determined by the camera selected for imaging and typically is 8 bits for most cameras.

3.2.17 *recording resolution (pixels/length), κ* —number of optical sensor elements (pixels) used to record an image of a region of length L on object.

3.2.18 *spatial resolution for encoded data*—one-half of the period of the highest frequency component contained in the frequency band of the encoded data.

3.2.19 *spatial resolution for optical data*—one-half of the period of the highest frequency component contained in the

frequency band of the optical data. Note that decoded data may have a lower spatial resolution due to the decoding process.

3.2.20 *systematic errors*—biased variations in the measurements due to the effects of test environment, hardware and/or software. Test environment effects include changes in temperature, humidity, lighting, out-of-plane displacements (for 2-D systems) etc. Hardware effects include lens aberrations, thermal drift in recording media, variations in sensing elements, interlacing of lines, phase lag due to refresh rates, depth of field for recording system, etc. Software effects include interpolation errors, search algorithm processes, image boundary effects, etc.

4. Description of General Optical Non-Contacting Strain Measurement Systems

4.1 Figs. 1 and 2 show schematics of typical moiré and digital image correlation setups used to make displacement field measurements. In its most basic form, an optical non-contacting strain measurement system such as shown in Figs. 1 and 2, consists of five components. The five components are (a) an illumination source, (b) a test specimen, (c) a method to apply forces to the specimen, (d) a recording media to obtain images of the object at each load level of interest and (e) an image analysis procedure to convert the encoded deformation information into strain data. Since the encoded information in the optical images may be related either to displacement field components or to the displacement gradient field components, image analysis procedures will be somewhat different for each case. However, regardless of which form is encoded in the images, the images are the Basic Data and the displacement fields and the strain fields will be part of the Derived Data. This guide is primarily concerned with general features of (a) the illumination source, (d) image recording components, and (e) image analysis procedures. ASTM standards for specimen

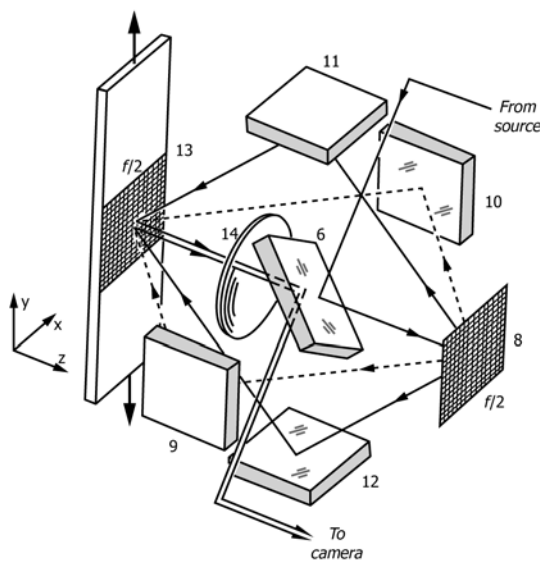

(a) Compact moiré interferometer

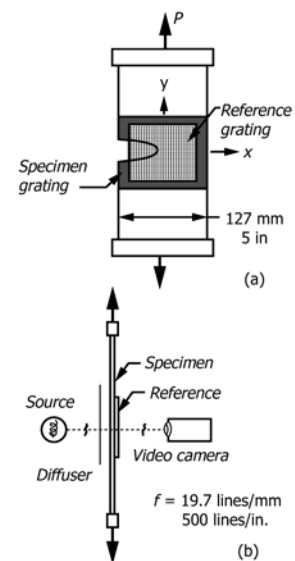

(b) Moiré with white light

FIG. 1 Typical Optical Moiré Systems for In-Plane Displacement Measurement

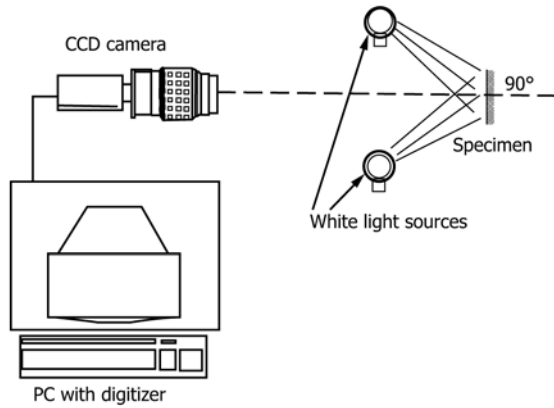

(a) 2-D Digital image correlation setup

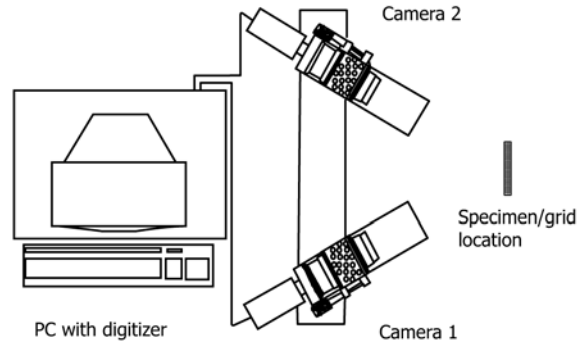

(b) 3-D Digital image correlation setup

FIG. 2 Typical Digital Image Correlation Setups For (a) In-Plane Displacement Measurement and (b) Three-Dimensional Displacement Measurement

design and loading, such as Test Methods E8 for tensile testing of metals or Test Method E399 for plane strain fracture toughness provide the basis for (b, c).

5. Error Sources

5.1 At each stage of the flow of data in the measurement system, errors can be introduced. These are considered in the sequence in which they occur in this guide.

5.2 *Errors Introduced in Recording Process*—Since the media used to record Basic Data can introduce additional errors in the Derived Data, each set of experimental data must include a detailed description of the recording media used. If a digital camera system is used to record images, data to be included should be the camera manufacturer, camera output form (for example, analog or digital), camera spatial resolution, data acquisition board type, pixel quantization level (for example, 8 bits), ratio of pixel dimensions, lens type and manufacturer. When photographic film is used to record images, the film characteristics and method of processing, as well as lens type and manufacturer used in imaging should be documented.

5.3 *Errors Due to Extraneous Vibrations*—Depending upon the measurement resolution, system vibrations can increase errors in the encoded information which may result in additional extraction errors. Provided that the period of vibration is sufficiently small relative to the integration time, and the amplitude of the disturbance is small relative to the quantity being measured, sensor averaging may reduce the effect of vibrations on the displacement fields and the strain fields.

5.4 *Errors Due to Lighting Variations*—Since the Basic Data is image data, lighting variations during the experiment may affect (1) the actual encoded information (for example, phase shift in coherent methods) and (2) extraction of the encoded information. For incoherent methods, light variations of several quantization levels may degrade the Derived Data extracted from the images. Similar effects are possible for coherent methods if there are, for instance, slight changes in the wavelength of the illumination. In both cases, use of image processing methods that are insensitive to lighting variations

(for example, normalized cross correlation) will increase the accuracy of the extracted data.

5.5 *Errors Due to Rigid Body Motion*—Depending upon the measurement resolution, rigid body translation and/or rotation may severely impact the ability to extract encoded information from the image data. For example, if the translation is large compared to the measurement resolution and the optical resolution of the recording media is low, then the high frequency encoded information may be lost.

5.6 *Errors in Extraction Process*—The encoded information extracted from the recorded images is degraded by errors introduced by the image processing method used. Errors introduced by the extraction process can be a combination of random errors as well as systematic errors (for example, peak-estimator bias or drift in Fourier correlation methods). Improved methods for image processing may significantly reduce extraction errors and special care should be taken to reduce systematic errors.

5.6.1 For example, one can define an engineering measure of normal strain along the “n” direction as:

$$\epsilon_{nn} = \frac{(L_n^{final} - L_n^{initial})}{L_n^{initial}}$$

Here, ϵ_{nn} is defined by $L_n^{final} = [(L_n + \Delta u_n)^2 + (\Delta u_{t1})^2 + (\Delta u_{t2})^2]^{1/2}$ and $(\Delta u_n, \Delta u_{t1}, \Delta u_{t2})$ are finite changes in displacement along the perpendicular directions n, t_1 and t_2 for points at either end of line L_n . Thus, errors in strain ϵ_{nn} can be due to (1) errors in the initial length of the line element and (2) errors in the displacement components $(\Delta u_n, \Delta u_{t1}, \Delta u_{t2})$. In both cases, extraction of Derived Data from the Basic Data is the source of error.

5.7 *Errors in Processing Extracted Data*—Errors are introduced when the form of extracted Derived Data in 5.6 is processed to obtain strain data. This process can involve a wide range of mathematical operations including (1) numerical differentiation of derived displacement data and (2) smoothing of displacement or displacement gradient data. Errors introduced by the choice of post-processing method can include, but